

TECHNICAL DATA SHEET

LPI® Power Over Ethernet Protector



Features

- Max impulse current 20 kA 8/20 μ s for data and power
- Protection for CAT5 10/100 Base-T data and 48 V DC power signals
- Simple plug-in connection using industry standard RJ-45 sockets
- IP65 rated weatherproof housing for outdoor installation
- Configurable for either standard PoE or proprietary systems
- Fully automated with all protection components self-resetting once a surge has passed

Technical Data:

Ordering code:	POE RJ45-CAT5	
Connectors:	2 x Modular RJ-45 Female Jacks (8 Contact, 8 Position) 1 x M4 earth stud	
Pin Configuration:	STANDARD 1: Data TX- 2: Data TX+ 3: Data RX- 6: Data RX+ 4+5: +48 VDC 7+8: 48 VDC RTN	PROPRIETARY 1: Data TX- 2: Data TX+ 3: Data RX- 6: Data RX+ 4: 48 VDC RTN 5: +48 VDC 7 & 8: SYNC
Clamping Voltage: (1 kV/ μ s impulse)	Power: < 60 V Data: < 15 V	
Maximum Impulse Current: (8/20 μ s impulse)	Power: 20 kA Data: 20 kA	
Max. Transmission Speed:	100 Mbit/s (CAT 5)	
Operating Temperature:	- 40°C to +80°C, 0 – 90%	
Dimensions:	115 x 65 x 55 mm	
Enclosure:	IP65 rated ABS Cable entry via IP65 rated cable glands	
Warranty:	5 Years – Contact LPI for full warranty details	
Weight:	300 g	

Note: Our PoE unit only compatible with 100BASE-TX or 10BASE-T. unfortunately, other protocols (1000BASE-T, 2.5GBASE-T, 5GBASE-T and 10GBASE-T) are not compatible with our unit.

10/100 units also comes with 2 modes. Mode A and Mode B. Our unit works only with Mode B.

	Mode A		Mode B
	10/100 (Mixed DC & Data)		10/100 (DC on Spare Lines)
1	Rx+	DC+	Rx+
2	Rx-	DC+	Rx-
3	Tx+	DC-	Tx+
4	unused		DC+
5	unused		DC+
6	Tx-	DC+	Tx-
7	unused		DC-
8	unused		DC-

TECHNICAL DATA SHEET

Installation:

In order to provide complete protection and ensure correct operation of the protector unit, one LPI POE RJ45 CAT5 unit should be installed at each end of an exposed cable run.

1. Remove the lid from the LPI POE RJ45 CAT5 unit to access the mounting holes. Mount the unit in the desired location with the cable glands facing down, to avoid water ingress into the housing.
2. Apply one section of the supplied self-amalgamating tape to the cables in the position shown in Figure 1, approximately 110 mm from the end of the connector. This will ensure a water tight fit around the cable gland once the cable is installed in the protector.
3. Connect the line cable to the input marked "LINE" and the equipment cable to the input marked "EQUIP". Secure the cable glands firmly around the cables.
4. Check to ensure the configuration jumper pins are in the correct location. For standard PoE configuration, the jumper pins should be positioned at the locations marked with a white ■. For the proprietary configuration, the jumper pins should be in the locations without a marking next to them. There should be 3 jumper pins for each of the LINE and EQUIP inputs.
5. Connect a minimum 2.5 mm² earth cable to the earth terminal post on the side of the housing. This should then be connected to the nearest earthing point via the shortest, most direct route.
6. Replace the lid and tighten the fixing screws. The unit is now installed.

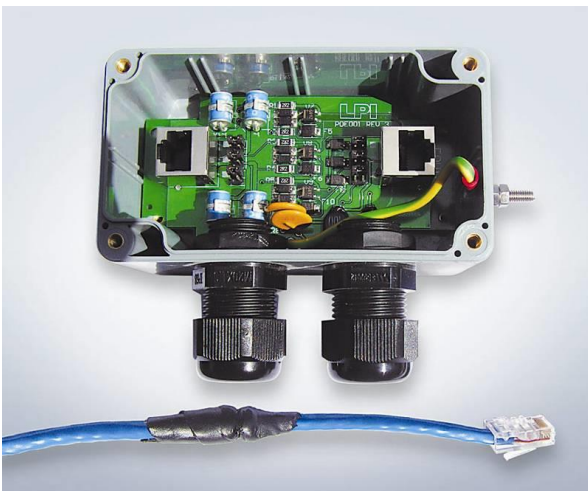
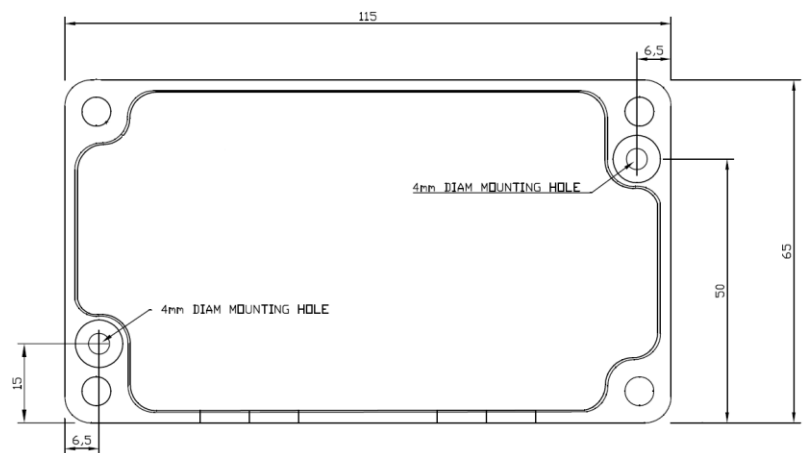
**Figure 1****Figure 2**

TECHNICAL DATA SHEET

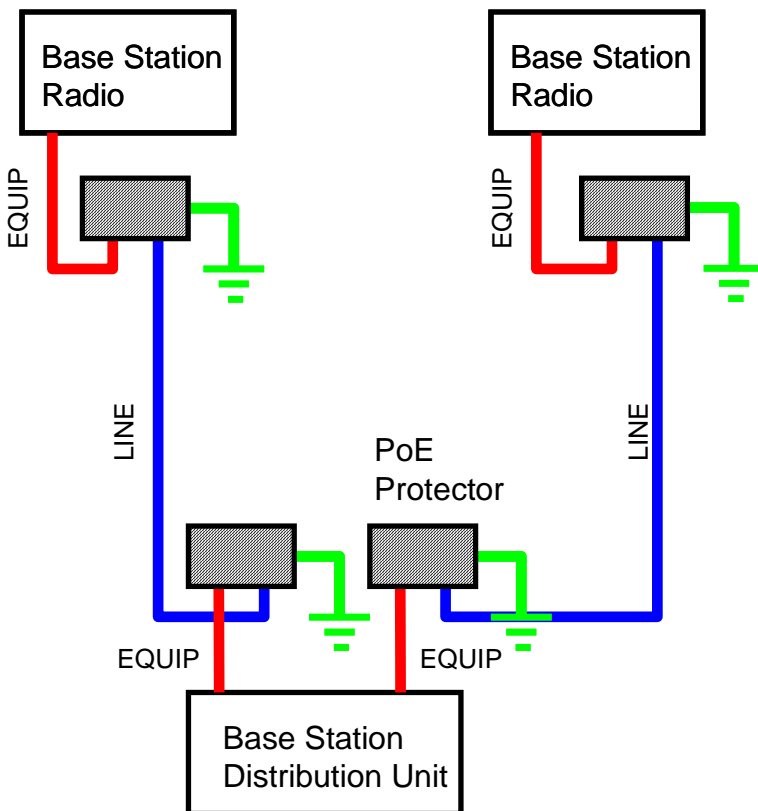

Typical Installation:

One PoE Protector should be installed at each end of the exposed cable run. This will ensure all equipment is adequately protected from induced surges on the Ethernet cable.

Current limiting resistors integral to the power protection circuit provide over-current protection, ensuring crowbar protection components will reset once the surge impulse has passed.

Figure 3



Figure 4 - Configuration Jumper pins are shown circled.